

N2312A013

Brushless DC Motor

Assembly Data	Symbol	Units	Value	
Reference Voltage	E	V	12	
No-Load Speed	S_{NL}	rpm (rad/s)	6,431	(673)
Continuous Torque (Max.) ¹	T_C	oz-in (N-m)	27	(1.9E-01)
Peak Torque (Stall) ^{1,2}	T_{PK}	oz-in (N-m)	70	(4.9E-01)
Weight	W_M	oz (g)	19	(524)
Motor Data				
Torque Constant	K_T	oz-in/A (N-m/A)	2.42	(1.71E-02)
Back-EMF Constant	K_E	V/krpm (V/rad/s)	1.79	(1.71E-02)
Resistance	R_T	Ω	0.15	
Inductance	L	mH	0.31	
No-Load Current	I_{NL}	A	0.23	
Peak Current (Stall) ^{1,2}	I_P	A	25.9	
Motor Constant ^{1,2}	K_M	oz-in/ \sqrt{W} (N-m/ \sqrt{W})	5.30	(3.74E-02)
Friction Torque	T_F	oz-in (N-m)	1.20	(8.5E-03)
Rotor Inertia	J_M	oz-in-s ² (kg-m ²)	1.7E-03	(1.2E-05)
Electrical Time Constant	τ_E	ms	2.10	
Mechanical Time Constant	τ_M	ms	8.5	
Viscous Damping	D	oz-in/krpm (N-m-s)	0.32	(2.2E-05)
Damping Constant	K_D	oz-in/krpm (N-m-s)	0.029	(2.0E-06)
Maximum Winding Temperature	θ_{MAX}	$^{\circ}F$ ($^{\circ}C$)	266	(130)
Thermal Impedance	R_{TH}	$^{\circ}F/watt$ ($^{\circ}C/watt$)	40	(4.2)
Thermal Time Constant	τ_{TH}	min	17.0	
Gearbox Data				
Encoder Data				

- Included Features**
- 4-Pole Rotor
 - Neodymium Magnets
 - 3-Phase Slotted Stator
 - 6-Slot Laminations
 - Stainless Steel Shaft
 - NEMA 23 Mounting
 - Ball Bearings
 - Hall Sensors
- Customization Options**
- Alternate Winding
 - Modified Output Shaft
 - Custom Cable Assembly
 - Spur or Planetary Gearbox
 - Optional Encoder
 - Fail-Safe Brake
 - Integral Electronics

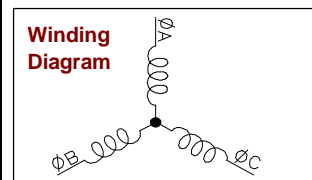

1 - Specified at max. winding temperature at 25°C ambient without heat sink. 2 - Theoretical values supplied for reference only.

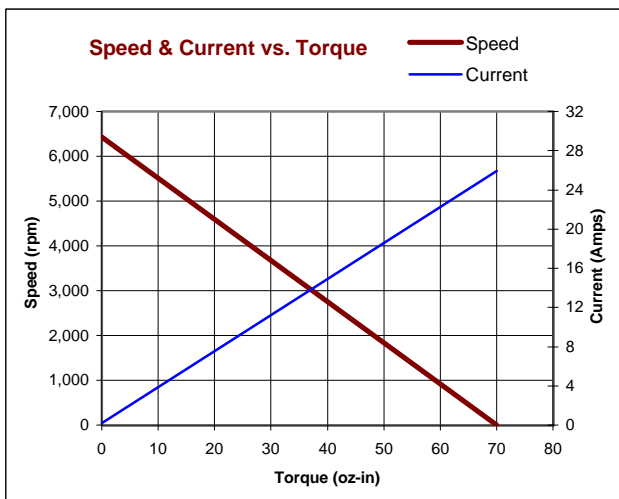

All values are nominal. Specifications subject to change without notice. Graphs are shown for reference only at maximum winding temperature.

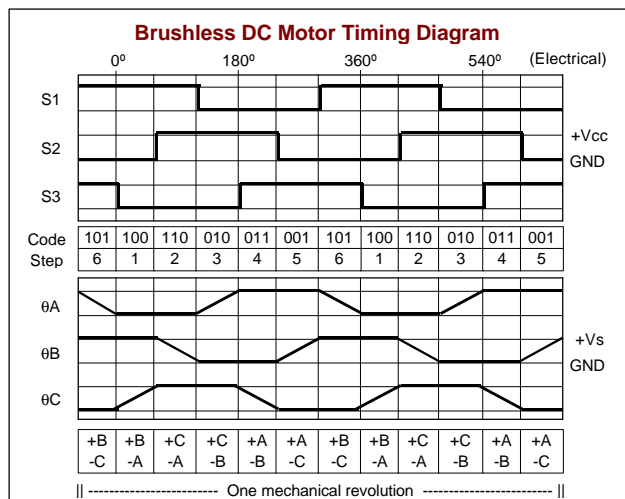

NOTICE: CONFIDENTIAL PROPRIETARY INFORMATION THIS PRINT CONTAINS IDEAS, INFORMATION, AND INTELLECTUAL PROPERTY WHICH ARE THE EXCLUSIVE PROPERTY OF PITTMAN, DIVISION OF PENN ENGINEERING & MANUFACTURING CORP. RECIPIENT MUST KEEP THE INFORMATION DISCLOSED HEREIN CONFIDENTIAL AND RECIPIENT IS EXPRESSLY PROHIBITED FROM COPYING OR PUBLICATION OF THIS PRINT EXCEPT TO OTHERS IN THEIR ORGANIZATION ON A NEED-TO-KNOW BASIS.

WIRING SEQUENCE

BROWN	MOTOR	ØA
RED	MOTOR	ØB
ORANGE	MOTOR	ØC
GREY	SENSOR	Ø1
BLUE	SENSOR	Ø2
WHITE	SENSOR	Ø3
VIOLET	SENSOR	Vcc
BLACK	SENSOR	GND
COLOR	FUNCTION	

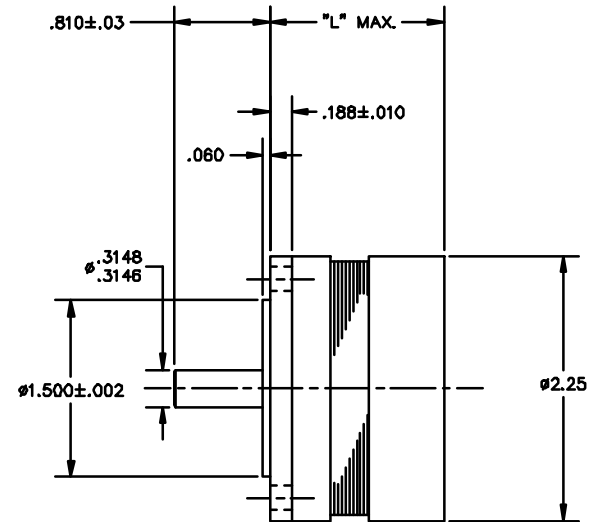
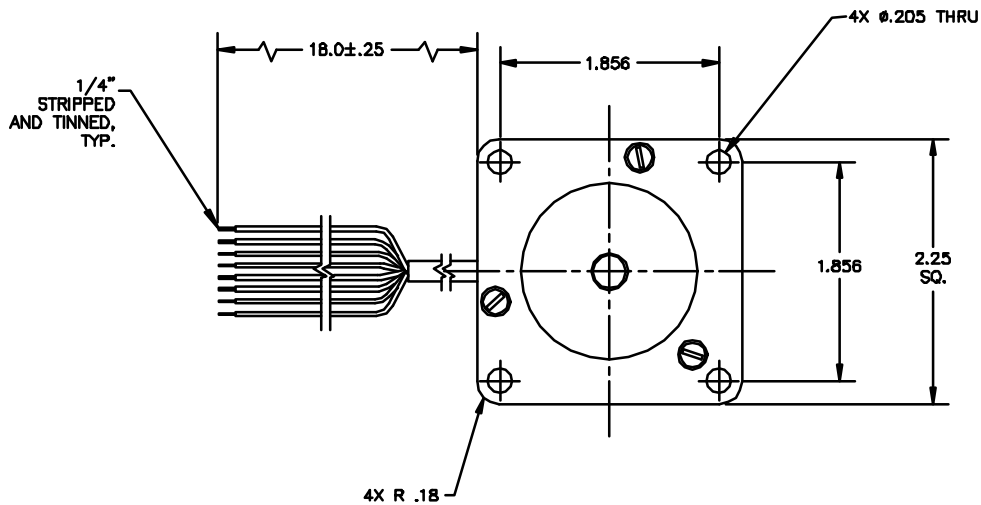

3.982	N2316
3.482	N2315
2.982	N2314
2.482	N2313
1.982	N2312
1.532	N2311
"L"	MOTOR

REVISIONS				
LTR	DESCRIPTION	DRFT/ENGR	DATE	APPR
A	PROTOTYPE RELEASE	TJK/TJK	8/16/99	KPW
B	REMOVED NOTE 7 FLAG	TJK/TJK	9/14/99	KPW
C	REMOVED CONNECTOR, UPDATED WIRING SEQUENCE	TJK/TJK	11/2/99	KPW
D	ADDED: MAX. UPDATED: "L" DIMENSION	TJK/TJK		
E	ADDED: N2313 & N2315	KJP	8/4/00	JVM
F	PRODUCTION RELEASE	KJP		

UNLESS OTHERWISE SPECIFIED DIMENSIONS ARE IN INCHES TOLERANCES ARE: FRACTION DECIMAL ANGLES $\pm 1/8$ $\pm .015$ ± 15 $\pm .010$ $\pm .005$ BREAK ALL SHARP EDGES	FILE: 150/626		
	DRAFTED BY: TJK DATE: 8/25/99		TITLE: SIZE 23 MOTOR OUTLINE
	ENGINEERED BY: TJK 8/25/99		
	APPROVED BY: KPW 8/27/99		
MATERIAL:	NEXT ASSY:	DWG. NO. B- 150-626	REV. F
FINISH:	USED ON:	SCALE:	SHEET 1 OF 1