

GM9236S027

Lo-Cog® DC Servo Gearmotor

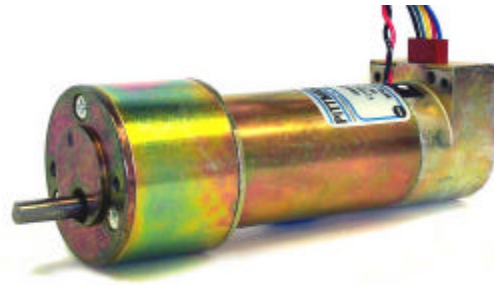

Assembly Data	Symbol	Units	Value	
Reference Voltage	E	V	24	
No-Load Speed	S _{NL}	rpm (rad/s)	71	(7.4)
Continuous Torque (Max.) ¹	T _C	oz-in (N-m)	480	(3.4E+00)
Peak Torque (Stall) ²	T _{PK}	oz-in (N-m)	2585	(1.8E+01)
Weight	W _M	oz (g)	23.7	(671)
Motor Data				
Torque Constant	K _T	oz-in/A (N-m/A)	6.49	(4.58E-02)
Back-EMF Constant	K _E	V/krpm (V/rad/s)	4.80	(4.58E-02)
Resistance	R _T	Ω	2.49	
Inductance	L	mH	2.63	
No-Load Current	I _{NL}	A	0.16	
Peak Current (Stall) ²	I _P	A	9.64	
Motor Constant	K _M	oz-in/√W (N-m/√W)	4.11	(2.90E-02)
Friction Torque	T _F	oz-in (N-m)	0.80	(5.6E-03)
Rotor Inertia	J _M	oz-in-s ² (kg-m ²)	1.0E-03	(7.1E-06)
Electrical Time Constant	τ _E	ms	1.06	
Mechanical Time Constant	τ _M	ms	8.5	
Viscous Damping	D	oz-in/krpm (N-m-s)	0.053	(3.5E-06)
Damping Constant	K _D	oz-in/krpm (N-m-s)	12.5	(8.5E-04)
Maximum Winding Temperature	θ _{MAX}	°F (°C)	311	(155)
Thermal Impedance	R _{TH}	°F/watt (°C/watt)	56.3	(13.5)
Thermal Time Constant	τ _{TH}	min	13.5	
Gearbox Data				
Reduction Ratio			65.5	
Efficiency ³			0.80	
Maximum Allowable Torque		oz-in (N-m)	500	(3.53)
Encoder Data				
Channels			3	
Resolution		CPR	500	

1 - Specified at max. winding temperature at 25°C ambient without heat sink. 2 - Theoretical values supplied for reference only.
3 - Effective gearbox efficiency for this unit improved by use of ball bearings.

Included Features

- 2-Pole Stator
- Ceramic Magnets
- Heavy-Gauge Steel Housing
- 7-Slot Armature
- Silicon Steel Laminations
- Stainless Steel Shaft
- Copper-Graphite Brushes
- Diamond Turned Commutator
- Motor Ball Bearings
- Output Ball Bearing
- Wide Face Gears

Customization Options

- Alternate Winding
- Sleeve or Ball Bearings
- Modified Output Shaft
- Custom Cable Assembly
- Special Brushes
- EMI/RFI Suppression
- Alternate Gear Material
- Special Lubricant
- Optional Encoder
- Fail-Safe Brake

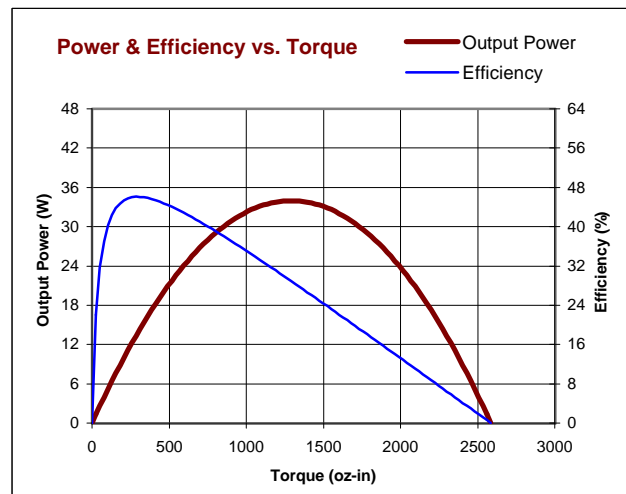
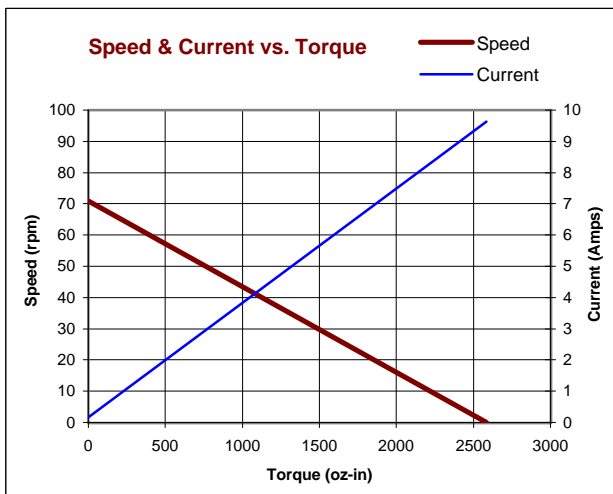

All values are nominal. Specifications subject to change without notice. Graphs are shown for reference only.

© 2001 Pittman.

NOTICE: CONFIDENTIAL PROPRIETARY INFORMATION THIS PRINT CONTAINS IDEAS, INFORMATION, AND INTELLECTUAL PROPERTY WHICH ARE THE EXCLUSIVE PROPERTY OF PITTMAN, DIVISION OF PENN ENGINEERING & MANUFACTURING CORP. RECIPIENT MUST KEEP THE INFORMATION DISCLOSED HEREIN CONFIDENTIAL AND RECIPIENT IS EXPRESSLY PROHIBITED FROM COPYING OR PUBLICATION OF THIS PRINT EXCEPT TO OTHERS IN THEIR ORGANIZATION ON A NEED-TO-KNOW BASIS.

REVISIONS				
LTR	DESCRIPTION	DRFT/ENGR	DATE	APPR
A	PRODUCTION RELEASE	DLF/DLF	10-24-94	JRM
B	.330 WAS .313	TMG/DLF		

1	GND
2	N.C./INDEX
3	CH. A
4	VCC.
5	CH. B
PIN CONNECTION	

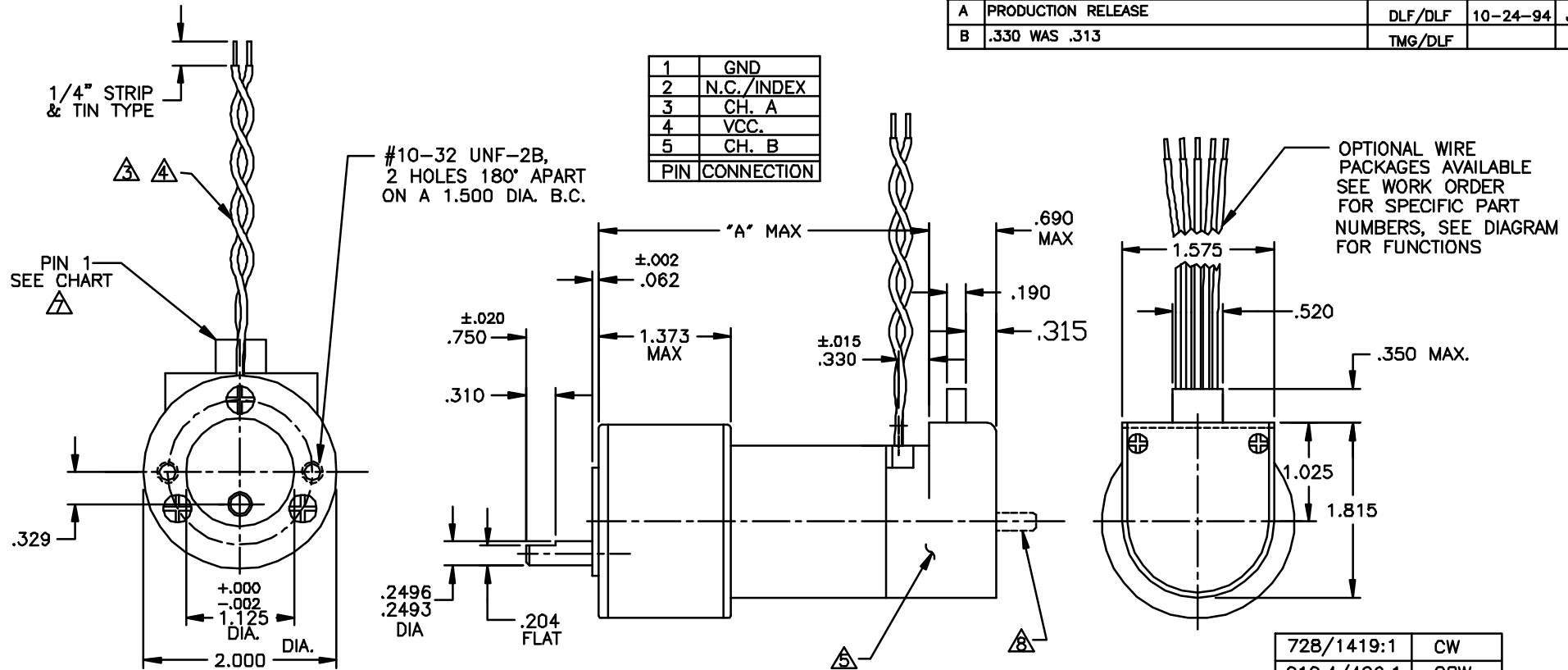

- NOTES:
- OUTPUT SHAFT ROTATION IS PER CHART, FIGURED WHILE VIEWING MOUNTING END WITH (+) POSITIVE VOLTAGE APPLIED TO RED MOTOR WIRE.
 - ENDPLAY .020 MAX. ON OUTPUT SHAFT, .015 MAX. ON MOTOR SHAFT.
 - STANDARD LEADS ARE 22 AWG. (7X30), PVC INSULATION, UL STYLE 1569/1007 ONE LEAD IS RED, ONE BLACK.
 - STANDARD LEAD LENGTH IS 18 ± 1/2".
 - ENCLOSED IS A HEDS-91X0 OPTICAL ENCODER MODULE. INDEX PULSE OPTIONAL. SEE DATA SHEET FOR LINE COUNT.
 - MAX TORQUE GEARBOX IS TO 175 oz.in. STANDARD GEARING, 300 oz.in. HIGH-TORQUE GEARING, AND 500 oz.in. WIDE FACE GEARING.
 - MOLEX CENTER CRIMP TERMINAL HOUSING 2695 SERIES, WILL ACCEPT MOLEX MATING TERMINALS 2759, PITTMAN P/N: 81-54-1.
 - OPTIONAL REAR SHAFT EXTENSION AVAILABLE (.1564/.1561 DIA.).

GM92X6	4.289
GM92X5	3.939
GM92X4	3.639
GM92X3	3.439
GM92X2	3.064
MODEL No.	"A" MAX

728/1419:1	CW
218.4/426:1	CCW
65.5/127.7:1	CW
19.7/38.3:1	CCW
5.9/11.5:1	CW
GEAR RATIO	SHAFT ROTATION

UNLESS OTHERWISE SPECIFIED DIMENSIONS ARE IN INCHES TOLERANCES ARE: FRACTION DECIMAL ANGLES ±1/84 ±.015 ±15	FILE: 150\413
BREAK ALL SHARP EDGES	DRAFTED BY DLF DATE 15 AUG 94
MATERIAL:	ENGINEERED BY DLF 15 AUG 94
FINISH:	APPROVED BY JR MELA 10-24-94
	NEXT ASSY:
	USED ON:

PITTMAN
A Division of Penn Engineering & Manufacturing Corp.
2000 West Chester Pike, P.O. Box 1000, West Chester, PA 19380

TITLE: OUTLINE & MOUNTING DIMENSIONS GM9200 SERIES MOTOR WITH H.P. ENCODER MODULE 9100

DWG. NO. **B- 150-413** REV. **B**

SCALE: NONE SHEET 1 OF 1