

## GM9234S033

Lo-Cog® DC Servo Gearmotor

Assembly Data	Symbol	Units	Value	
Reference Voltage	E	V	24	
No-Load Speed	S <sub>NL</sub>	rpm (rad/s)	21	(2.2)
Continuous Torque (Max.) <sup>1</sup>	T <sub>C</sub>	oz-in (N-m)	500	(3.5E+00)
Peak Torque (Stall) <sup>2</sup>	T <sub>PK</sub>	oz-in (N-m)	4199	(3.0E+01)
Weight	W <sub>M</sub>	oz (g)	20.3	(577)
Motor Data				
Torque Constant	K <sub>T</sub>	oz-in/A (N-m/A)	6.50	(4.59E-02)
Back-EMF Constant	K <sub>E</sub>	V/krpm (V/rad/s)	4.81	(4.59E-02)
Resistance	R <sub>T</sub>	Ω	4.62	
Inductance	L	mH	3.97	
No-Load Current	I <sub>NL</sub>	A	0.13	
Peak Current (Stall) <sup>2</sup>	I <sub>P</sub>	A	5.19	
Motor Constant	K <sub>M</sub>	oz-in/√W (N-m/√W)	3.01	(2.13E-02)
Friction Torque	T <sub>F</sub>	oz-in (N-m)	0.60	(4.2E-03)
Rotor Inertia	J <sub>M</sub>	oz-in-s <sup>2</sup> (kg-m <sup>2</sup> )	5.9E-04	(4.2E-06)
Electrical Time Constant	τ <sub>E</sub>	ms	0.85	
Mechanical Time Constant	τ <sub>M</sub>	ms	9.3	
Viscous Damping	D	oz-in/krpm (N-m-s)	0.039	(2.6E-06)
Damping Constant	K <sub>D</sub>	oz-in/krpm (N-m-s)	6.7	(4.5E-04)
Maximum Winding Temperature	θ <sub>MAX</sub>	°F (°C)	311	(155)
Thermal Impedance	R <sub>TH</sub>	°F/watt (°C/watt)	62.8	(17.1)
Thermal Time Constant	τ <sub>TH</sub>	min	12.0	
Gearbox Data				
Reduction Ratio			218.4	
Efficiency <sup>3</sup>			0.73	
Maximum Allowable Torque		oz-in (N-m)	500	(3.53)
Encoder Data				
Channels			3	
Resolution		CPR	500	

1 - Specified at max. winding temperature at 25°C ambient without heat sink. 2 - Theoretical values supplied for reference only.  
3 - Effective gearbox efficiency for this unit improved by use of ball bearings.

### Included Features

- 2-Pole Stator
- Ceramic Magnets
- Heavy-Gauge Steel Housing
- 7-Slot Armature
- Silicon Steel Laminations
- Stainless Steel Shaft
- Copper-Graphite Brushes
- Diamond Turned Commutator
- Motor Ball Bearings
- Output Ball Bearing
- Wide Face Gears

### Customization Options

- Alternate Winding
- Sleeve or Ball Bearings
- Modified Output Shaft
- Custom Cable Assembly
- Special Brushes
- EMI/RFI Suppression
- Alternate Gear Material
- Special Lubricant
- Optional Encoder
- Fail-Safe Brake

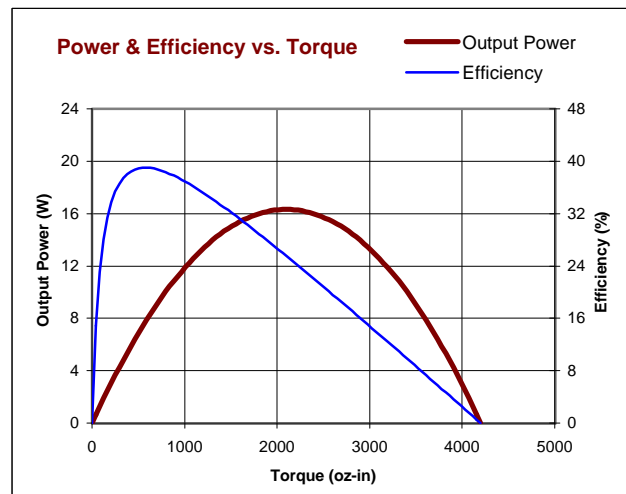
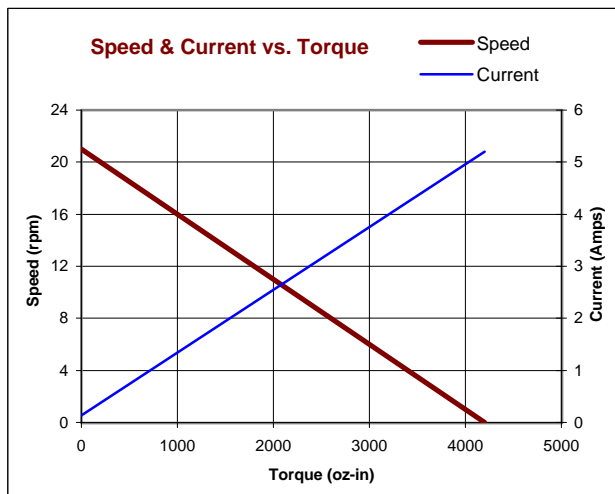

All values are nominal. Specifications subject to change without notice. Graphs are shown for reference only.

© 2001 Pittman.

NOTICE: CONFIDENTIAL PROPRIETARY INFORMATION THIS PRINT CONTAINS IDEAS, INFORMATION, AND INTELLECTUAL PROPERTY WHICH ARE THE EXCLUSIVE PROPERTY OF PITTMAN, DIVISION OF PENN ENGINEERING & MANUFACTURING CORP. RECIPIENT MUST KEEP THE INFORMATION DISCLOSED HEREIN CONFIDENTIAL AND RECIPIENT IS EXPRESSLY PROHIBITED FROM COPYING OR PUBLICATION OF THIS PRINT EXCEPT TO OTHERS IN THEIR ORGANIZATION ON A NEED-TO-KNOW BASIS.

REVISIONS				
LTR	DESCRIPTION	DRFT/ENGR	DATE	APPR
A	PRODUCTION RELEASE	DLF/DLF	10-24-94	JRM
B	.330 WAS .313	TMG/DLF		

1	GND
2	N.C./INDEX
3	CH. A
4	VCC.
5	CH. B
PIN CONNECTION	

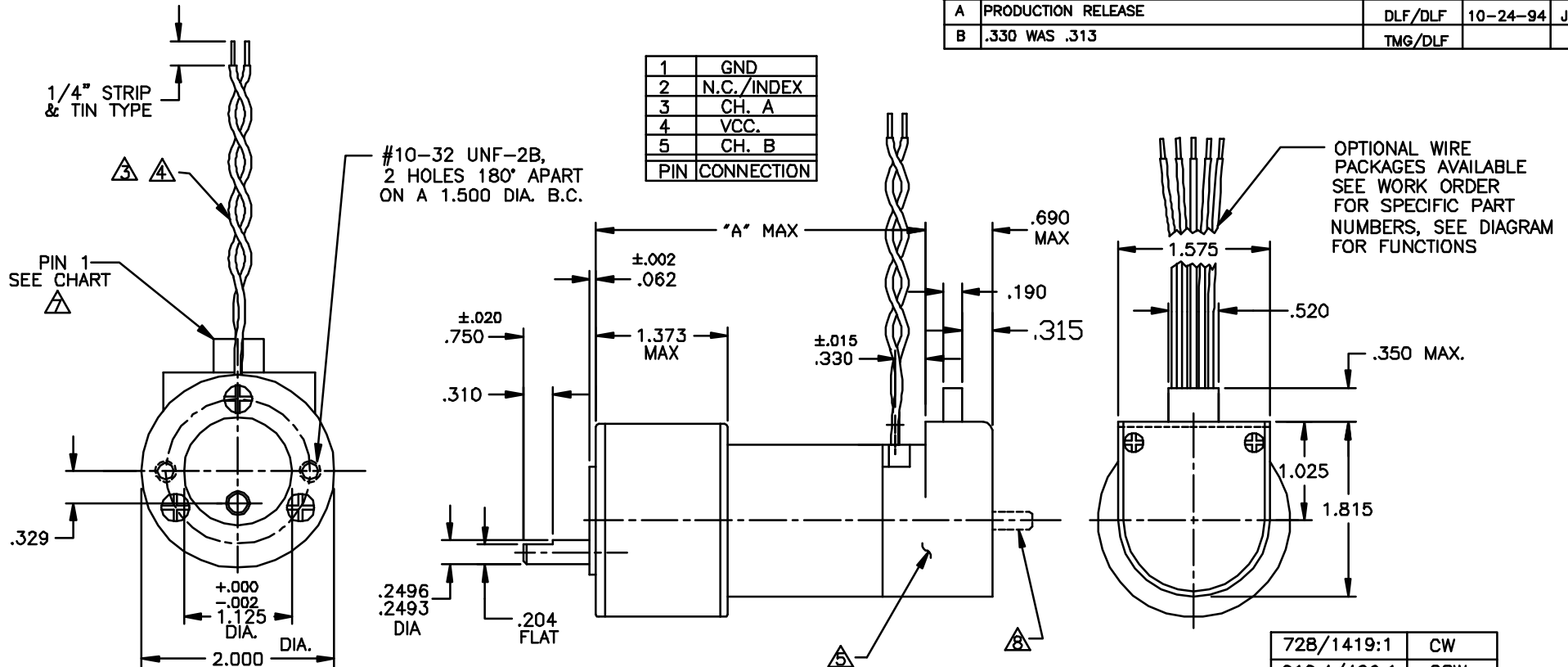

NOTES:

- OUTPUT SHAFT ROTATION IS PER CHART, FIGURED WHILE VIEWING MOUNTING END WITH (+) POSITIVE VOLTAGE APPLIED TO RED MOTOR WIRE.
- ENDPLAY .020 MAX. ON OUTPUT SHAFT, .015 MAX. ON MOTOR SHAFT.
- STANDARD LEADS ARE 22 AWG. (7X30), PVC INSULATION, UL STYLE 1569/1007 ONE LEAD IS RED, ONE BLACK.
- STANDARD LEAD LENGTH IS 18 ±1/2".
- ENCLOSED IS A HEDS-91X0 OPTICAL ENCODER MODULE. INDEX PULSE OPTIONAL. SEE DATA SHEET FOR LINE COUNT.
- MAX TORQUE GEARBOX IS TO 175 oz.in. STANDARD GEARING, 300 oz.in. HIGH-TORQUE GEARING, AND 500 oz.in. WIDE FACE GEARING.
- MOLEX CENTER CRIMP TERMINAL HOUSING 2695 SERIES, WILL ACCEPT MOLEX MATING TERMINALS 2759, PITTMAN P/N: 81-54-1.
- OPTIONAL REAR SHAFT EXTENSION AVAILABLE (.1564/.1561 DIA.).

GM92X6	4.289
GM92X5	3.939
GM92X4	3.639
GM92X3	3.439
GM92X2	3.064
MODEL No.	"A" MAX

728/1419:1	CW
218.4/426:1	CCW
65.5/127.7:1	CW
19.7/38.3:1	CCW
5.9/11.5:1	CW
GEAR RATIO	SHAFT ROTATION

UNLESS OTHERWISE SPECIFIED DIMENSIONS ARE IN INCHES TOLERANCES ARE: FRACTION DECIMAL ANGLES ±1/84 ±.015 ±1° ±.010 ±1° ±.005 ±.005		FILE: 150\413	
DRAFTED BY: DLF	DATE: 15 AUG 94	DRAWN BY: DLF	
ENGINEERED BY: DLF	DATE: 15 AUG 94	APPROVED BY: JR MELA	
APPROVED BY: JR MELA	DATE: 10-24-94	DATE: 10-24-94	
MATERIAL:	NEXT ASSY:	TITLE: OUTLINE & MOUNTING DIMENSIONS GM9200 SERIES MOTOR WITH H.P. ENCODER MODULE 9100	
FINISH:	USED ON:	DWG. NO. B-	REV. B
		SCALE: NONE	SHEET 1 OF 1