



GM8724S022

Lo-Cog® DC Gearmotor

Assembly Data	Symbol	Units	Value	
Reference Voltage	E	V	24	
No-Load Speed	S _{NL}	rpm (rad/s)	75	(7.9)
Continuous Torque (Max.) ¹	T _C	oz-in (N-m)	113	(8.0E-01)
Peak Torque (Stall) ²	T _{PK}	oz-in (N-m)	328	(2.3E+00)
Weight	W _M	oz (g)	8.4	(239)
Motor Data				
Torque Constant	K _T	oz-in/A (N-m/A)	6.18	(4.36E-02)
Back-EMF Constant	K _E	V/krpm (V/rad/s)	4.57	(4.36E-02)
Resistance	R _T	Ω	17.0	
Inductance	L	mH	9.35	
No-Load Current	I _{NL}	A	0.09	
Peak Current (Stall) ²	I _P	A	1.41	
Motor Constant	K _M	oz-in/√W (N-m/√W)	1.49	(1.05E-02)
Friction Torque	T _F	oz-in (N-m)	0.35	(2.5E-03)
Rotor Inertia	J _M	oz-in-s ² (kg-m ²)	2.3E-04	(1.6E-06)
Electrical Time Constant	τ _E	ms	0.54	
Mechanical Time Constant	τ _M	ms	14.7	
Viscous Damping	D	oz-in/krpm (N-m-s)	0.020	(1.4E-06)
Damping Constant	K _D	oz-in/krpm (N-m-s)	1.6	(1.1E-04)
Maximum Winding Temperature	θ _{MAX}	°F (°C)	311	(155)
Thermal Impedance	R _{TH}	°F/watt (°C/watt)	70.5	(21.4)
Thermal Time Constant	τ _{TH}	min	10.7	
Gearbox Data				
Reduction Ratio			60.5	
Efficiency ³			0.78	
Maximum Allowable Torque		oz-in (N-m)	175	(1.24)
Encoder Data				

1 - Specified at max. winding temperature at 25°C ambient without heat sink. 2 - Theoretical values supplied for reference only.
3 - Effective gearbox efficiency for this unit improved by use of ball bearings.

Included Features

- 2-Pole Stator
- Ceramic Magnets
- Heavy-Gauge Steel Housing
- 7-Slot Armature
- Silicon Steel Laminations
- Stainless Steel Shaft
- Copper-Graphite Brushes
- Diamond Turned Commutator
- Motor Ball Bearings
- Output Ball Bearing
- Wide Face Gears

Customization Options

- Alternate Winding
- Sleeve or Ball Bearings
- Modified Output Shaft
- Custom Cable Assembly
- Special Brushes
- EMI/RFI Suppression
- Alternate Gear Material
- Special Lubricant
- Optional Encoder
- Fail-Safe Brake

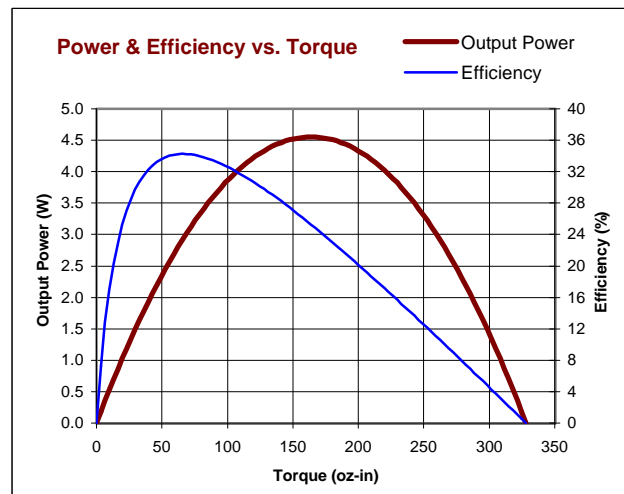
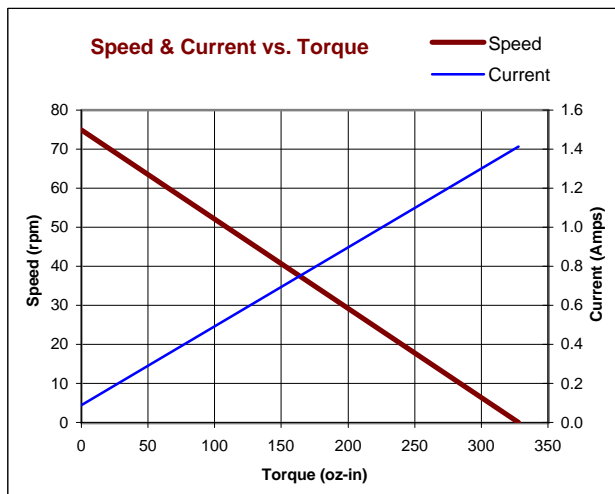

All values are nominal. Specifications subject to change without notice. Graphs are shown for reference only.

© 2001 Pittman.

NOTICE: CONFIDENTIAL PROPRIETARY INFORMATION THIS PRINT CONTAINS IDEAS, INFORMATION, AND INTELLECTUAL PROPERTY WHICH ARE THE EXCLUSIVE PROPERTY OF PITTMAN, DIVISION OF PENN ENGINEERING & MANUFACTURING CORP. RECIPIENT MUST KEEP THE INFORMATION DISCLOSED HEREIN CONFIDENTIAL AND RECIPIENT IS EXPRESSLY PROHIBITED FROM COPYING OR PUBLICATION OF THIS PRINT EXCEPT TO OTHERS IN THEIR ORGANIZATION ON A NEED-TO-KNOW BASIS

REVISIONS				
LTR	DESCRIPTION	DRFT/ENGR	DATE	APPR
H	REDRAWN, UPDATED TO CURRENT STD.	DLF	6/28/94	JVM
J	UPDATED TO CURRENT STD.	RJS/RJS		

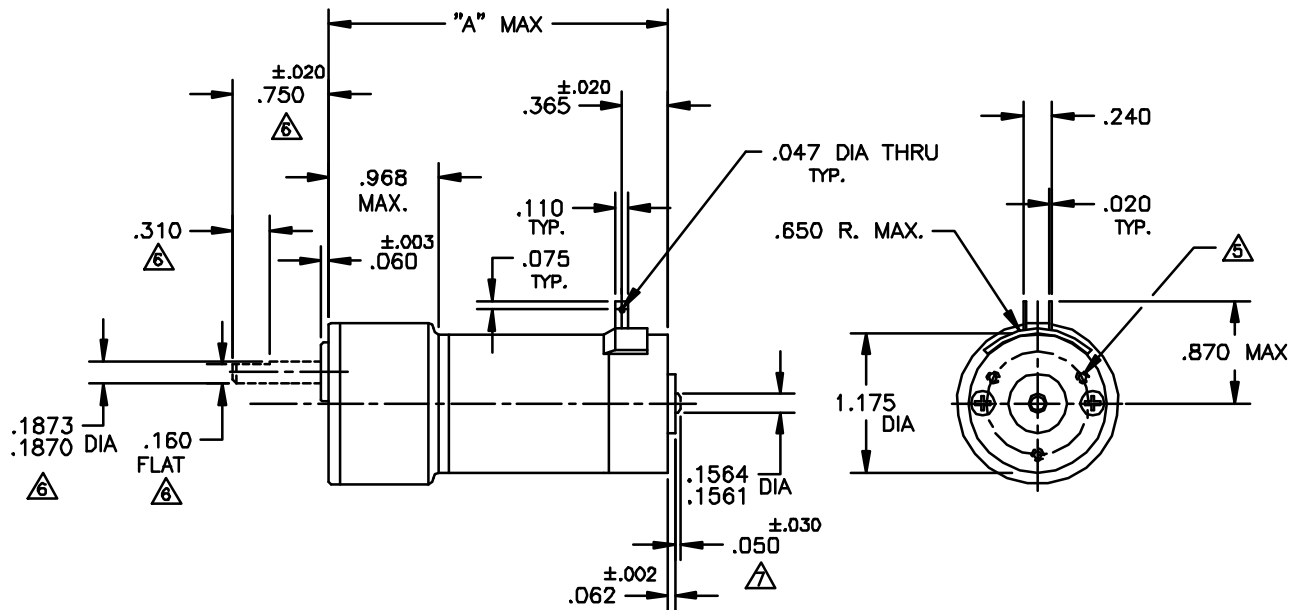
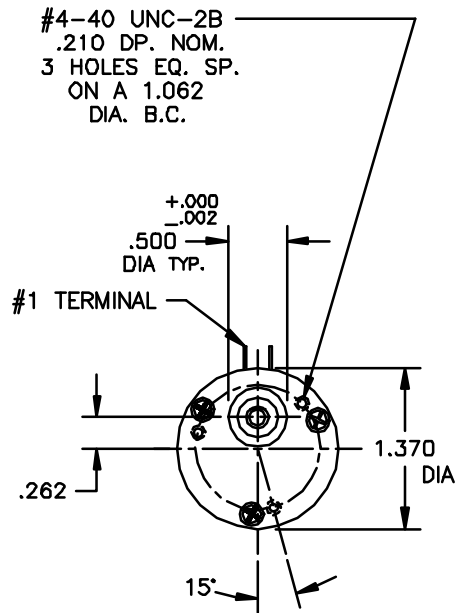

NOTES:

- SHAFT ROTATION IS SHOWN WHILE VIEWING MOUNTING END, WITH POSITIVE (+) VOLTAGE APPLIED TO # 1 TERMINAL.
 - TERMINALS ARE PLATED FOR SOLDERING.
 - MAX. GEARBOX TORQUE RATING IS 100 OZ.IN., STANDARD SINTERED GEARS.
MAX. GEARBOX TORQUE RATING IS 160 OZ.IN., CUT STEEL GEARS.
 - ENDPLAY .020 MAX. ON OUTPUT SHAFT, .015 MAX. ON MOTOR SHAFT.
- △ OPTIONAL MOUNTING PATTERN #2-56 UNC-2B, (3) HOLES EQUALLY SPACED ON A .875 DIA. B.C., .125 MAX. THREAD DEPTH.
- △ ALL SHAFT DIMENSIONS SHOWN ARE STD. (10-385). FOR ALL OTHER CONFIGURATIONS REFER TO DATA SHEET FOR PART NUMBERS.
- △ OPTIONAL REAR SHAFT EXTENSIONS AVAILABLE.

GEAR RATIO	DIRECTION		
187/96:1	CCW	3.285	GM87X4
60.5/31:1	CW	3.035	GM87X3
19.5/10:1	CCW	2.910	GM87X2
6.3:1	CW	"A" MAX.	MODEL NO.

UNLESS OTHERWISE SPECIFIED DIMENSIONS ARE IN INCHES TOLERANCES ARE: FRACTION DECIMAL ANGLES ±1/64 .0015 ±1° XX ±.010 XXX ±.005	FILE:	150/28		
	DRAFTED BY:	DLF		DATE:
BREAK ALL SHARP EDGES	ENGINEERED BY:	DLF	APPROVED BY:	JVM
MATERIAL:	APPROVED BY:	JVM	DATE:	6/28/94
FINISH:	NEXT ASSY:		TITLE:	OUTLINE & MOUNTING DIMENSIONS GM87XX STD. GEARBOX
	USED ON:		DWG. NO.	150-28
			SCALE:	D.N.S.
			SHEET	1 OF 1