



9237S010

Lo-Cog® DC Motor

| Assembly Data | Symbol | Units | Value | |
|---------------------------------------|------------------|---|---------|------------|
| Reference Voltage | E | V | 24 | |
| No-Load Speed | S _{NL} | rpm (rad/s) | 5,331 | (558) |
| Continuous Torque (Max.) ¹ | T _C | oz-in (N-m) | 11.5 | (8.1E-02) |
| Peak Torque (Stall) ² | T _{PK} | oz-in (N-m) | 77 | (5.4E-01) |
| Weight | W _M | oz (g) | 16 | (439) |
| Motor Data | | | | |
| Torque Constant | K _T | oz-in/A (N-m/A) | 6.00 | (4.24E-02) |
| Back-EMF Constant | K _E | V/krpm (V/rad/s) | 4.44 | (4.24E-02) |
| Resistance | R _T | Ω | 1.85 | |
| Inductance | L | mH | 1.97 | |
| No-Load Current | I _{NL} | A | 0.18 | |
| Peak Current (Stall) ² | I _P | A | 13.0 | |
| Motor Constant | K _M | oz-in/√W (N-m/√W) | 4.41 | (3.11E-02) |
| Friction Torque | T _F | oz-in (N-m) | 0.80 | (5.6E-03) |
| Rotor Inertia | J _M | oz-in-s ² (kg-m ²) | 1.2E-03 | (8.5E-06) |
| Electrical Time Constant | τ _E | ms | 1.06 | |
| Mechanical Time Constant | τ _M | ms | 8.9 | |
| Viscous Damping | D | oz-in/krpm (N-m-s) | 0.055 | (3.7E-06) |
| Damping Constant | K _D | oz-in/krpm (N-m-s) | 14 | (9.7E-04) |
| Maximum Winding Temperature | θ _{MAX} | °F (°C) | 311 | (155) |
| Thermal Impedance | R _{TH} | °F/watt (°C/watt) | 52.2 | (11.2) |
| Thermal Time Constant | τ _{TH} | min | 13.8 | |
| Gearbox Data | | | | |
| | | | | |
| | | | | |
| | | | | |
| Encoder Data | | | | |
| | | | | |
| | | | | |

Included Features

- 2-Pole Stator
- Ceramic Magnets
- Heavy-Gauge Steel Housing
- 7-Slot Armature
- Silicon Steel Laminations
- Stainless Steel Shaft
- Copper-Graphite Brushes
- Diamond Turned Commutator
- Motor Ball Bearings

Customization Options

- Alternate Winding
- Sleeve or Ball Bearings
- Modified Output Shaft
- Custom Cable Assembly
- Special Brushes
- EMI/RFI Suppression
- Spur or Planetary Gearbox
- Special Lubricant
- Optional Encoder
- Fail-Safe Brake

1 - Specified at max. winding temperature at 25°C ambient without heat sink. 2 - Theoretical values supplied for reference only.

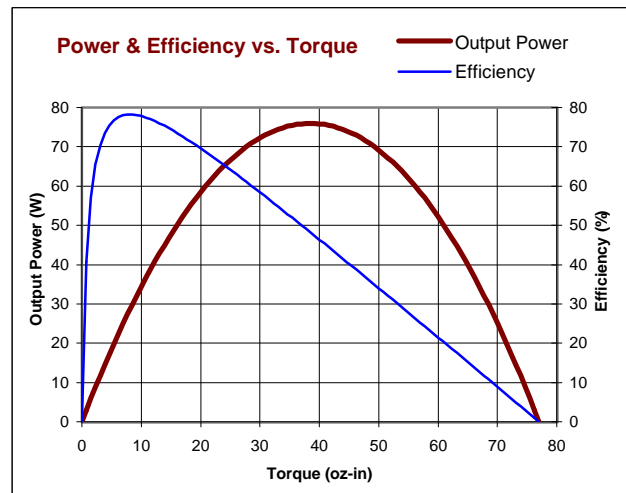
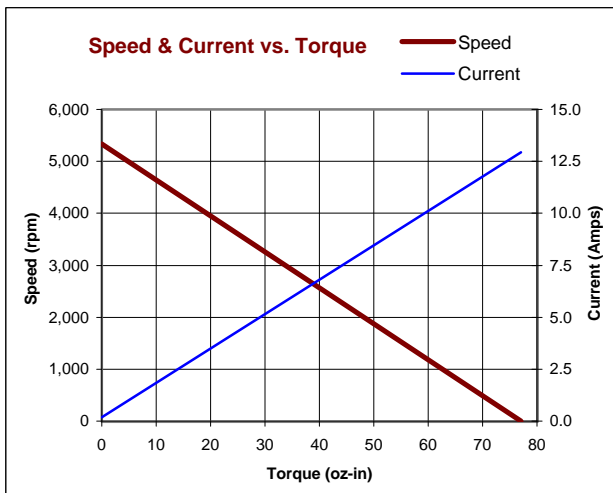

All values are nominal. Specifications subject to change without notice. Graphs are shown for reference only.

© 2001 Pittman.

NOTICE: CONFIDENTIAL PROPRIETARY INFORMATION THIS PRINT CONTAINS IDEAS, INFORMATION, AND INTELLECTUAL PROPERTY WHICH ARE THE EXCLUSIVE PROPERTY OF PITTMAN, DIVISION OF PENN ENGINEERING & MANUFACTURING CORP. RECIPIENT MUST KEEP THE INFORMATION DISCLOSED HEREIN CONFIDENTIAL AND RECIPIENT IS EXPRESSLY PROHIBITED FROM COPYING OR PUBLICATION OF THIS PRINT EXCEPT TO OTHERS IN THEIR ORGANIZATION ON A NEED-TO-KNOW BASIS.

| REVISIONS | | | | |
|-----------|------------------------------|-----------|---------|------|
| LTR | DESCRIPTION | DRFT/ENGR | DATE | APPR |
| D | REDRAWN & REVISED | RJS/RJS | 3/20/96 | JRM |
| E | 1/4" STRIP & TIN WAS "STRIP" | KUH/KUH | | |

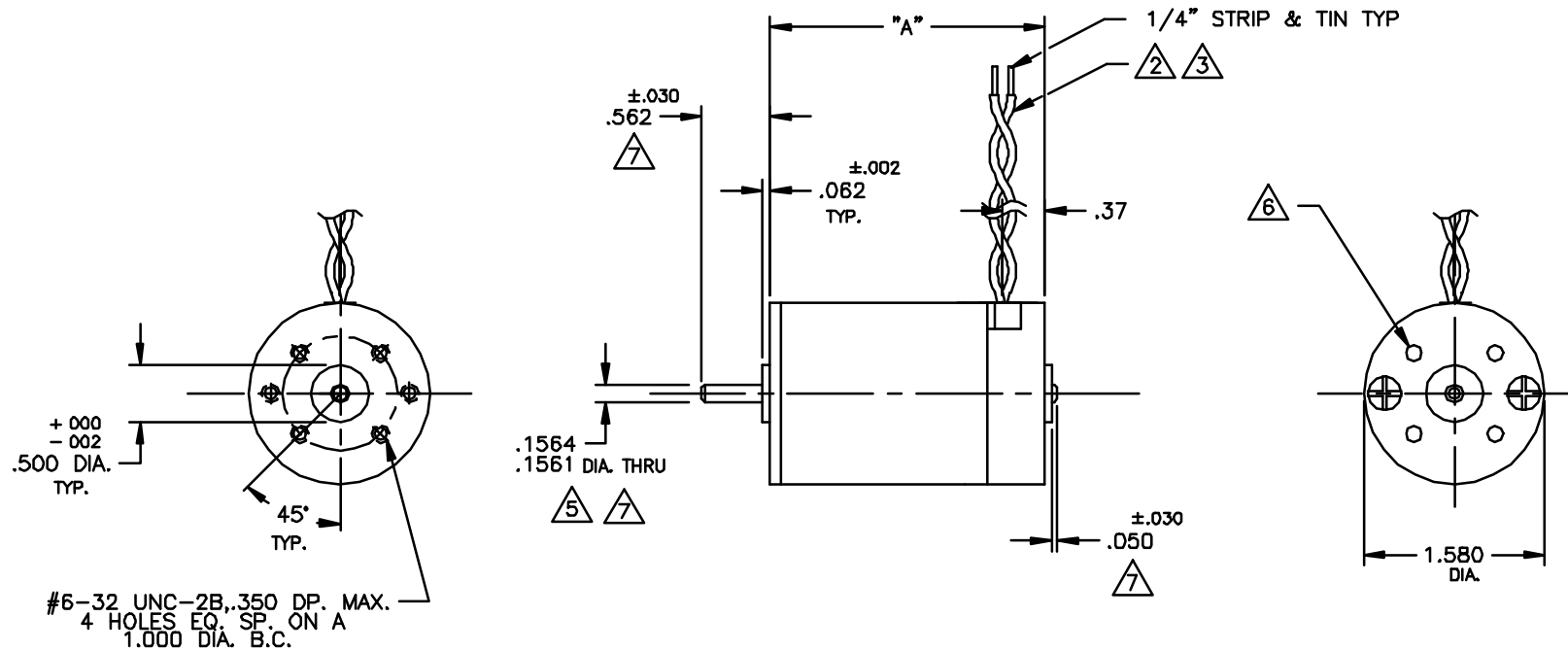

#6-32 UNC-2B,.350 DP. MAX.
4 HOLES EQ. SP. ON A
1.000 DIA. B.C.

NOTES:

1. SHAFT ROTATION IS CW VIEWING MOUNTING END WITH POSITIVE (+) VOLTAGE APPLIED TO RED LEAD.
- 2 LEADS ARE 22 AWG (7X30) PVC INSULATION, UL STYLE 1569/1007. RED AND BLACK
- 3 STANDARD LEAD LENGTH IS $18" \pm 1/2"$
4. ENDPLAY-.015 MAX. FOR SLEEVE BEARING MOTORS. BALL BEARING MOTORS ARE PRE-LOADED PER SPEC. P-107
- 5 OPTIONAL SHAFT DIA. $.1246/.1243$ IS AVAILABLE ONLY WITH THE 94X2 AND 94X3 MOTOR LENGTHS.
- 6 OPTIONAL REAR ENDBELL MOUNTING PATTERN #6-32 UNC-2B, $.180$ MAX THREAD PENETRATION, 4 HOLES EQ. SP. ON A 1.000 DIA B.C.
- 7 ALL SHAFT DIMENSIONS NOTED ARE STANDARD (10-631-00): FOR ALL OTHER SHAFT CONFIGURATIONS REFER TO DATA SHEET FOR PART #'S

| | |
|---------|-----------|
| 3.053 | 92X6 |
| 2.703 | 92X5 |
| 2.403 | 92X4 |
| 2.203 | 92X3 |
| 1.828 | 92X2 |
| "A" MAX | MODEL No. |

| | | | | |
|---|--|-----------------|--|--|
| UNLESS OTHERWISE SPECIFIED DIMENSIONS ARE IN INCHES TOLERANCES ARE: FRACTION DECIMAL ANGLES $\pm 1/84$ $\pm .015$ $\pm 1^\circ$ $\pm .010$ $\pm .005$ | | FILE: | DATE: 3/20/95 | |
| BREAK ALL SHARP EDGES | | DRAFTED BY: RJS | ENGINEERED BY: RJS | |
| MATERIAL: | | APPROVED BY: | NEXT ASSY: | |
| FINISH: | | USED ON: | | |
| | | | TITLE: OUTLINE AND MTG. DIMS. 92XX SERIES MOTOR | |
| DWG. NO. B-150-409 | | REV. E | | |
| SCALE: NONE | | SHEET 1 | | |