



9233S013

Lo-Cog® DC Motor

Assembly Data	Symbol	Units	Value	
Reference Voltage	E	V	24	
No-Load Speed	S _{NL}	rpm (rad/s)	5,993	(628)
Continuous Torque (Max.) ¹	T _C	oz-in (N-m)	4.7	(3.3E-02)
Peak Torque (Stall) ²	T _{PK}	oz-in (N-m)	32	(2.2E-01)
Weight	W _M	oz (g)	9	(252)
Motor Data				
Torque Constant	K _T	oz-in/A (N-m/A)	5.28	(3.73E-02)
Back-EMF Constant	K _E	V/krpm (V/rad/s)	3.90	(3.73E-02)
Resistance	R _T	Ω	3.94	
Inductance	L	mH	3.29	
No-Load Current	I _{NL}	A	0.15	
Peak Current (Stall) ²	I _P	A	6.09	
Motor Constant	K _M	oz-in/√W (N-m/√W)	2.66	(1.88E-02)
Friction Torque	T _F	oz-in (N-m)	0.60	(4.2E-03)
Rotor Inertia	J _M	oz-in-s ² (kg-m ²)	4.6E-04	(3.2E-06)
Electrical Time Constant	τ _E	ms	0.84	
Mechanical Time Constant	τ _M	ms	9.3	
Viscous Damping	D	oz-in/krpm (N-m-s)	0.034	(2.3E-06)
Damping Constant	K _D	oz-in/krpm (N-m-s)	5.2	(3.5E-04)
Maximum Winding Temperature	θ _{MAX}	°F (°C)	311	(155)
Thermal Impedance	R _{TH}	°F/watt (°C/watt)	66.4	(19.1)
Thermal Time Constant	τ _{TH}	min	11.1	
Gearbox Data				
Encoder Data				

Included Features

- 2-Pole Stator
- Ceramic Magnets
- Heavy-Gauge Steel Housing
- 7-Slot Armature
- Silicon Steel Laminations
- Stainless Steel Shaft
- Copper-Graphite Brushes
- Diamond Turned Commutator
- Motor Ball Bearings

Customization Options

- Alternate Winding
- Sleeve or Ball Bearings
- Modified Output Shaft
- Custom Cable Assembly
- Special Brushes
- EMI/RFI Suppression
- Spur or Planetary Gearbox
- Special Lubricant
- Optional Encoder
- Fail-Safe Brake

1 - Specified at max. winding temperature at 25°C ambient without heat sink. 2 - Theoretical values supplied for reference only.

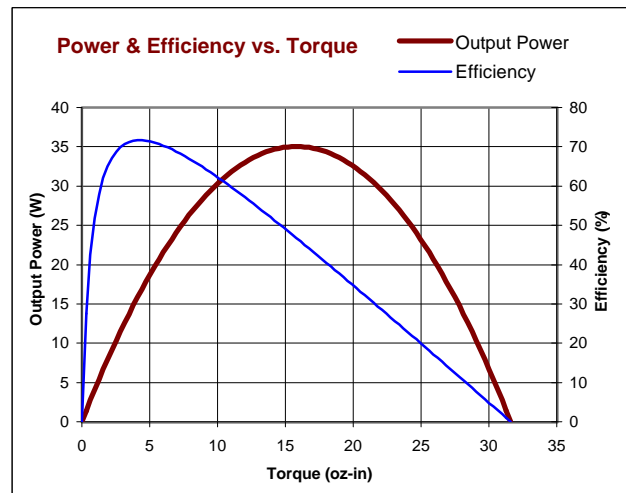
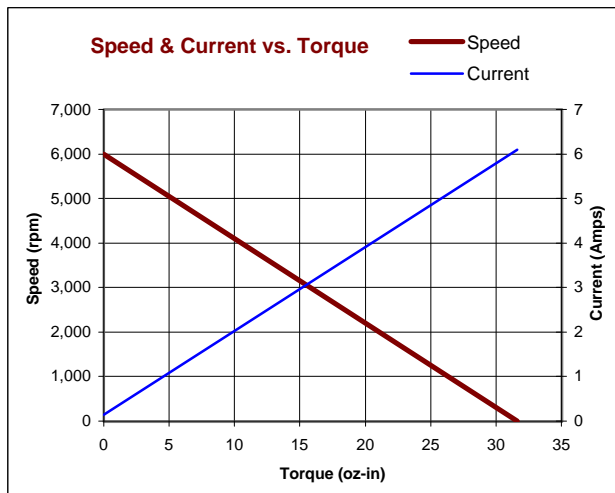

All values are nominal. Specifications subject to change without notice. Graphs are shown for reference only.

© 2001 Pittman.

NOTICE: CONFIDENTIAL PROPRIETARY INFORMATION THIS PRINT CONTAINS IDEAS, INFORMATION, AND INTELLECTUAL PROPERTY WHICH ARE THE EXCLUSIVE PROPERTY OF PITTMAN, DIVISION OF PENN ENGINEERING & MANUFACTURING CORP. RECIPIENT MUST KEEP THE INFORMATION DISCLOSED HEREIN CONFIDENTIAL AND RECIPIENT IS EXPRESSLY PROHIBITED FROM COPYING OR PUBLICATION OF THIS PRINT EXCEPT TO OTHERS IN THEIR ORGANIZATION ON A NEED-TO-KNOW BASIS.

REVISIONS				
LTR	DESCRIPTION	DRFT/ENGR	DATE	APPR
D	REDRAWN & REVISED	RJS/RJS	3/20/96	JRM
E	1/4" STRIP & TIN WAS "STRIP"	KUH/KUH		

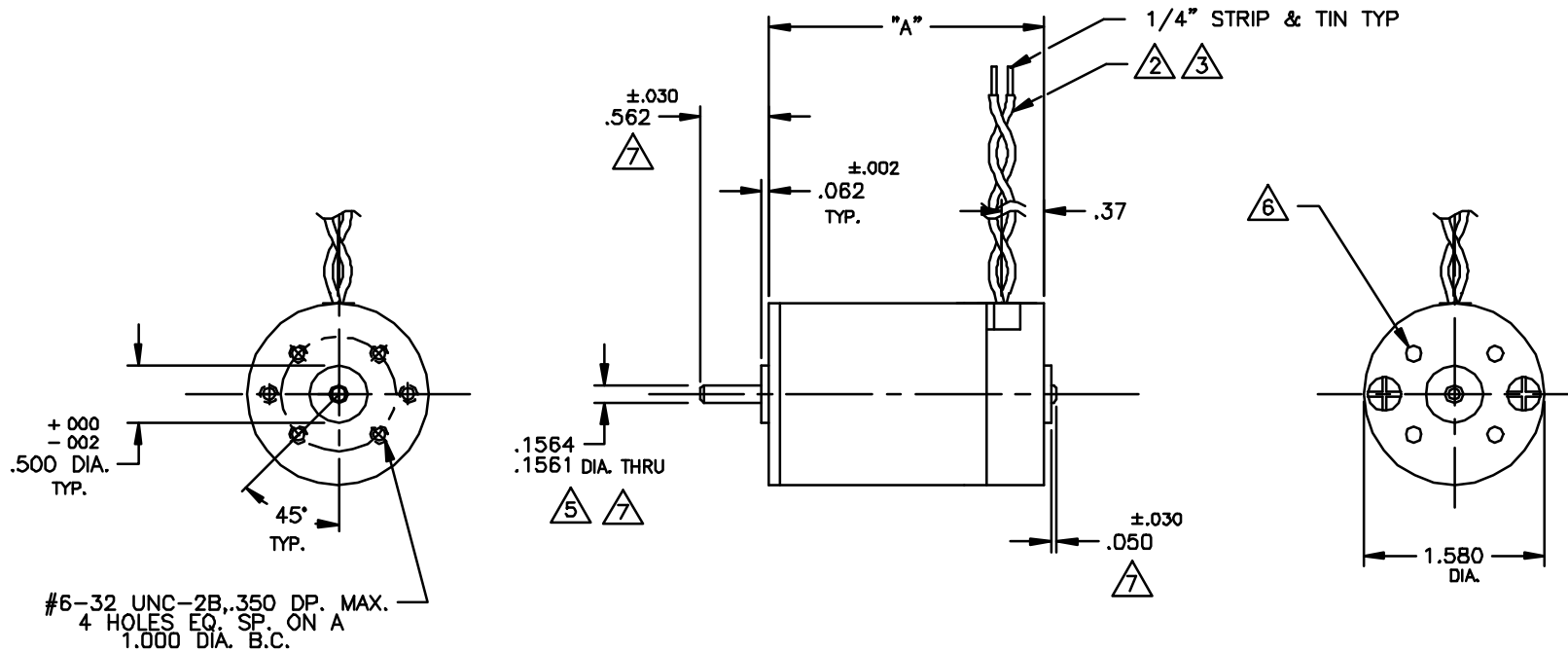

#6-32 UNC-2B,.350 DP. MAX.
4 HOLES EQ. SP. ON A
1.000 DIA. B.C.

NOTES:

- SHAFT ROTATION IS CW VIEWING MOUNTING END WITH POSITIVE (+) VOLTAGE APPLIED TO RED LEAD.
- LEADS ARE 22 AWG (7X30) PVC INSULATION, UL STYLE 1569/1007. RED AND BLACK
- STANDARD LEAD LENGTH IS $18" \pm 1/2"$
- ENDPLAY-.015 MAX. FOR SLEEVE BEARING MOTORS. BALL BEARING MOTORS ARE PRE-LOADED PER SPEC. P-107
- OPTIONAL SHAFT DIA. $.1246/.1243$ IS AVAILABLE ONLY WITH THE 94X2 AND 94X3 MOTOR LENGTHS.
- OPTIONAL REAR ENDBELL MOUNTING PATTERN #6-32 UNC-2B, $.180$ MAX THREAD PENETRATION, 4 HOLES EQ. SP. ON A 1.000 DIA B.C.
- ALL SHAFT DIMENSIONS NOTED ARE STANDARD (10-631-00); FOR ALL OTHER SHAFT CONFIGURATIONS REFER TO DATA SHEET FOR PART #'S

3.053	92X6
2.703	92X5
2.403	92X4
2.203	92X3
1.828	92X2
"A" MAX	MODEL No.

UNLESS OTHERWISE SPECIFIED DIMENSIONS ARE IN INCHES TOLERANCES ARE: FRACTION DECIMAL ANGLES $\pm 1/84$ $\pm .015$ $\pm 1^\circ$ $\pm .010$ $\pm .005$		FILE:	DATE: 3/20/95	
BREAK ALL SHARP EDGES		DRAFTED BY: RJS	ENGINEERED BY: RJS	
MATERIAL:		APPROVED BY:	NEXT ASSY:	
FINISH:		USED ON:		
			TITLE: OUTLINE AND MTG. DIMS. 92XX SERIES MOTOR	
DWG. NO. B-		150-409		REV. E
SCALE: NONE			SHEET 1	